

CH & C

KINGSBURY BEARING SYSTEMS

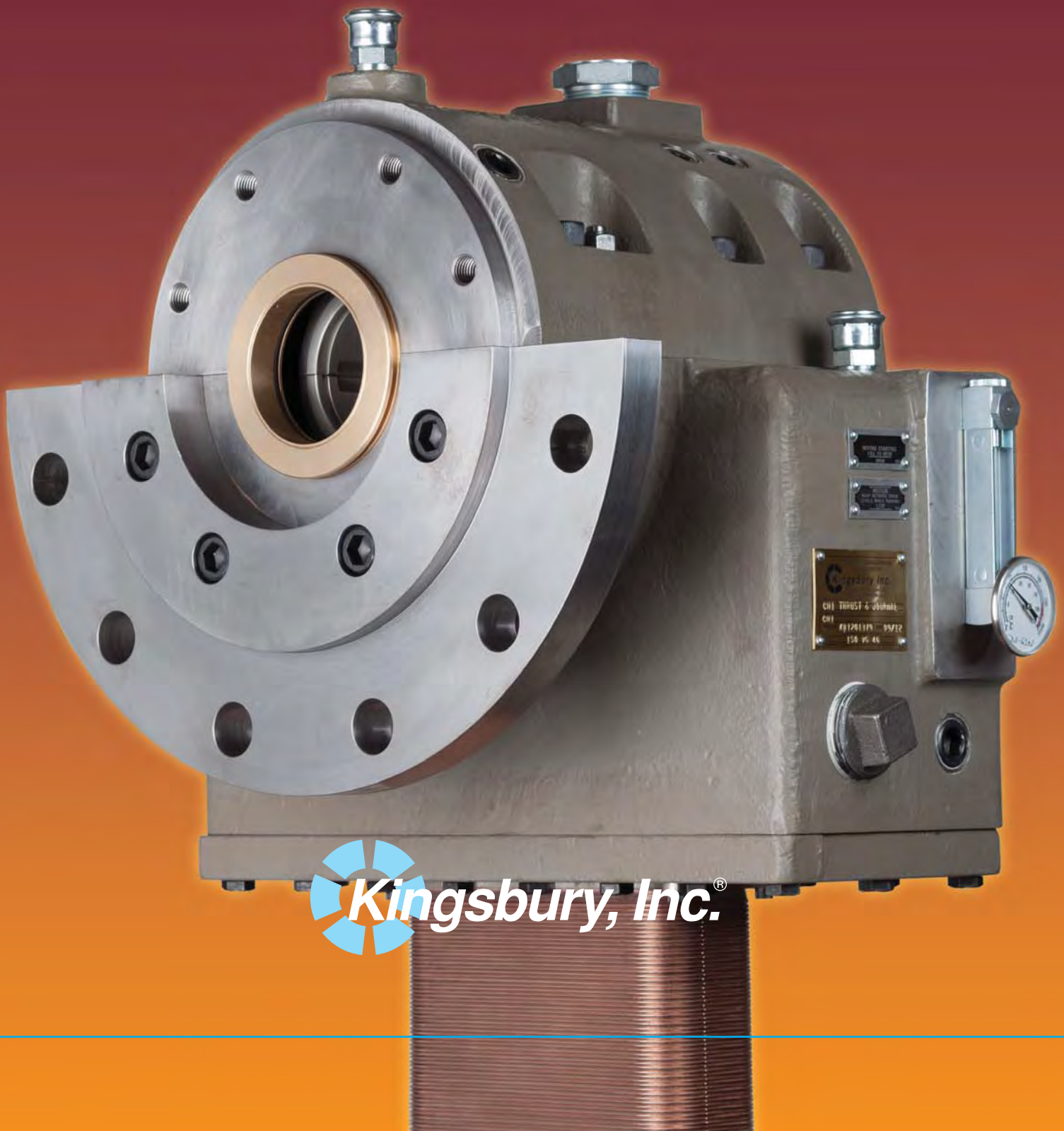

 **Kingsbury, Inc.**[®]



TABLE OF CONTENTS

INTRODUCTION.	3
ADVANTAGES OF KINGSBURY'S CH SYSTEM	4
GENERAL DESCRIPTION	6
HOW THE CH LUBRICATION SYSTEM WORKS	8
BEARING SELECTION	10
CH BEARING DIMENSIONAL DATA.	12
C BEARING DIMENSIONAL DATA.	13
PERFORMANCE DATA CURVES	14
OPTIONS AND INSTRUMENTATION	18



The Kingsbury CH Bearing System integrates a fully self-contained, flange-mounted, horizontal equalizing double thrust bearing with a self-aligning journal bearing (CH); and a remote, separately mounted journal bearing (C).

At the heart of every CH unit is a self-contained, load-equalizing thrust bearing. The system eliminates the need for an electric motor/ pump, emergency pump, accumulator, rundown tank, or other special arrangements for oil lubrication. No additional motor control system or any electric power is required to circulate the oil. And since no separate lube system is required, the cost savings are significant.

System lubrication is autonomous, provided by means of a viscosity pump driven by shaft rotation. This pump consists of the combination of the built-in mechanical oil circulator and the rotating collar, which draws oil up from the sump as soon as the shaft begins to rotate. As long as the shaft rotates, pumping action is achieved. No priming is necessary since the pump inlets are always submerged. Pumping action is bidirectional and automatically adjusts with shaft rotation.

The pressure and flow generated by this pump force the oil out through passages in the housing to lubricate both thrust bearings and the internal journal bearing. The pressure in the thrust cavity then drives the hot oil through the oil cooler and then back into the oil sump. The fewer the restrictions in the system, the more the circulator can pump.

Sufficient flow and pressure are developed by the CH unit that it can be evaluated for supplying oil to a separate, remote journal bearing: for example, the system prime mover. Please contact your Kingsbury Sales Engineer if you wish to have the CH lubricate additional equipment.

QUALITY STANDARDS:

KINGSBURY, INC.
ISO 9001: 2008 Registered

ADVANTAGES OF KINGSBURY'S CH SYSTEM

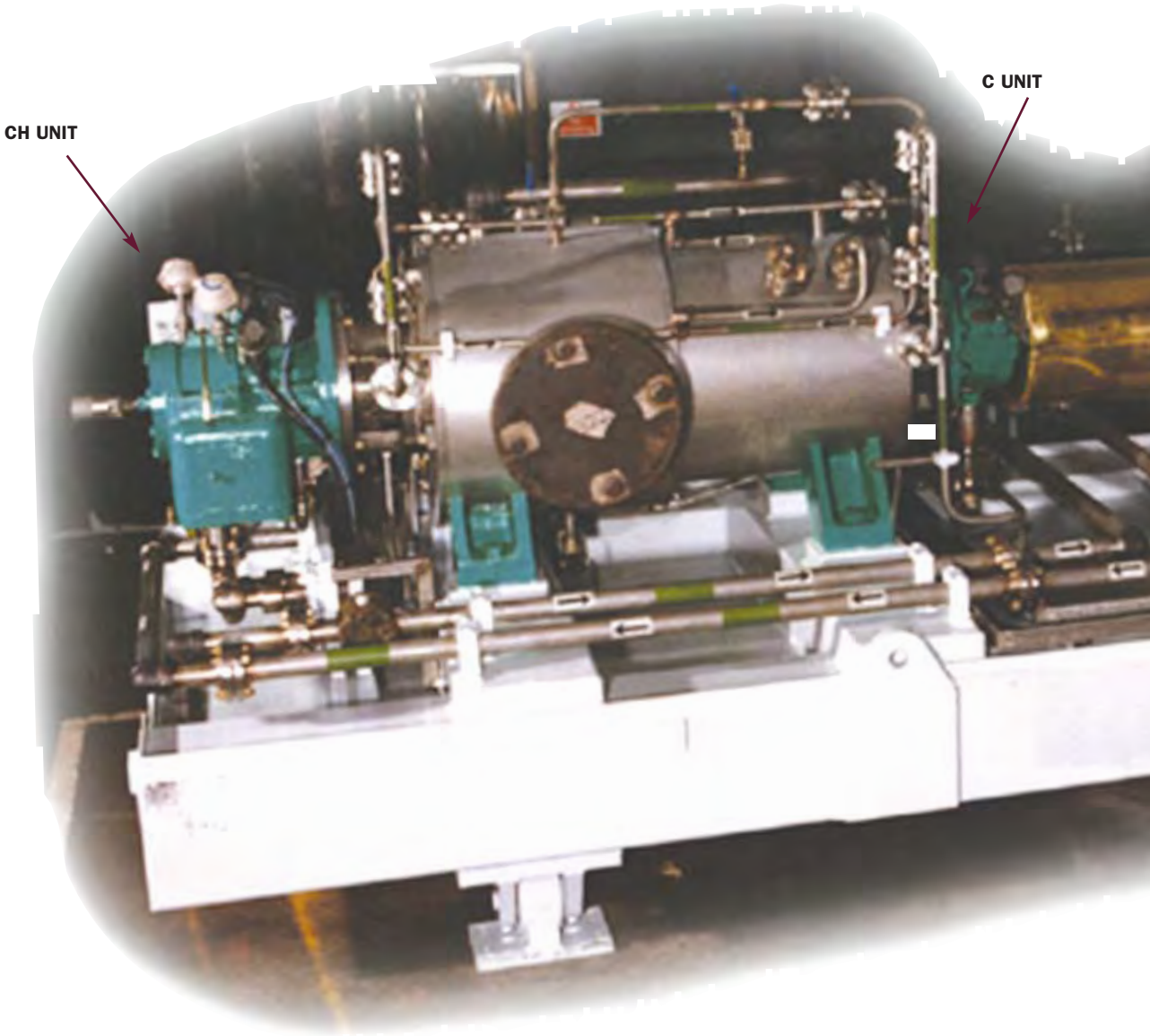

Only Kingsbury's CH Bearing System integrates:
1) a non-drive-end (NDE) unit with a double, equalizing thrust bearing, a journal bearing, and an oil circulator within a single

unified housing; and 2) a drive-end (DE) unit with an integral journal bearing in a second housing of its own. Other designs necessitate purchasing thrust and journal bearings separately, and

then still require additional components, like a machined housing and external lubrication system.

The Kingsbury CH system is integrated, reliable, and saves

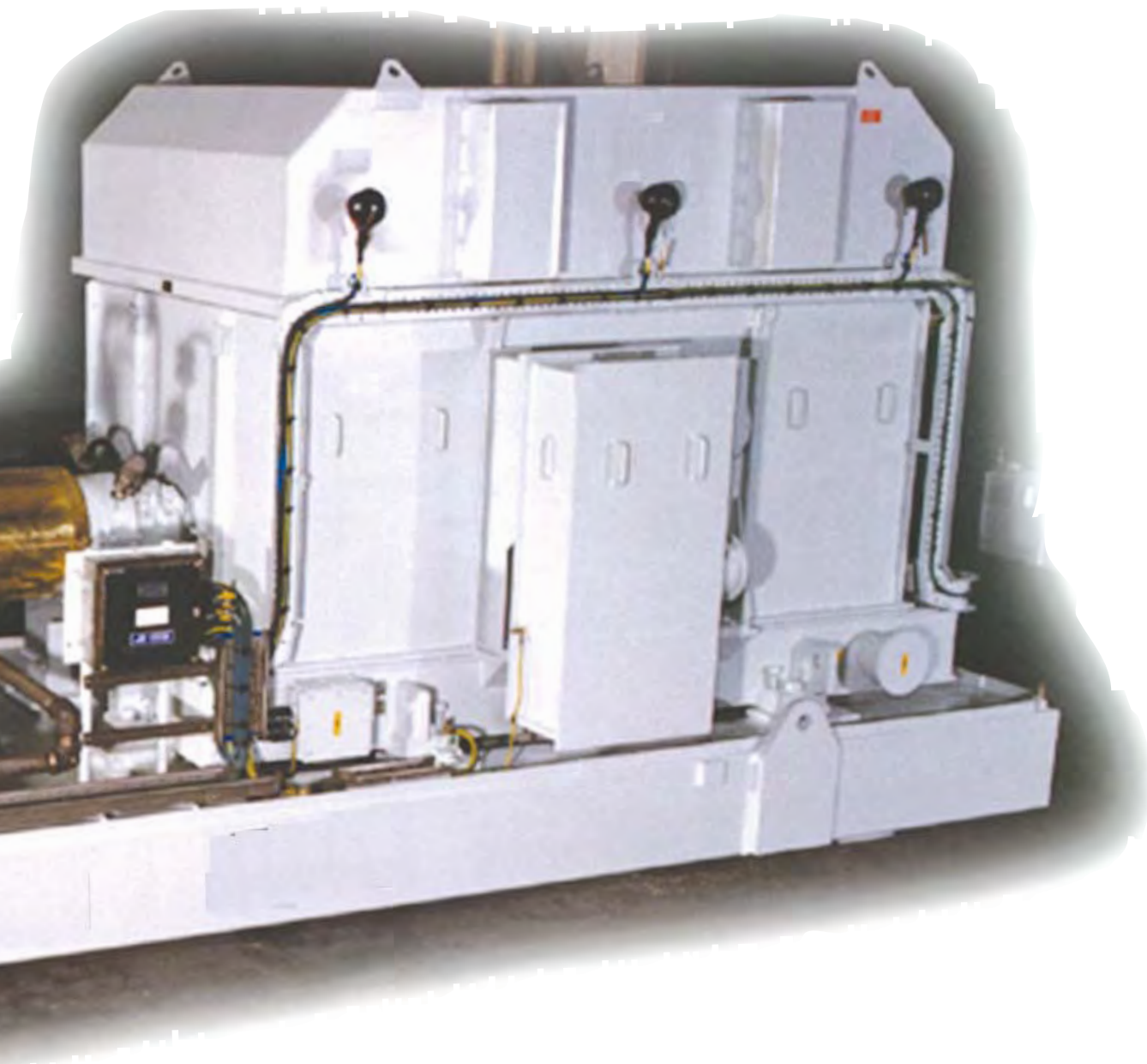

initial cost. CH bearing users have seen the savings first hand, reporting that when all is said and done, the CH costs considerably less to install on high-performance pumps. The CH Bearing System's simple

design has the same reliability as a full API lubrication system. The CH further demonstrates its superiority through its low maintenance, reduced weight and smaller footprint.



GENERAL DESCRIPTION

CH System

Kingsbury's complete CH system includes two separate components: the CH unit which includes thrust and journal bearings and provides the lubrication, and the C unit, with a remotely mounted journal bearing.

CH Unit

Thrust Bearings

Kingsbury utilizes equalizing thrust bearings which conform to API 610 requirements. The Kingsbury principle and the workings of the equalizing thrust bearing are fully described in our EQH-1 catalog.

Journal Bearing

The CH unit contains an integral, self-aligning journal bearing designed to accurately locate the shaft under all loading conditions. Journal bearing diameters are based on the machine's shaft requirements. Each housing will accommodate a choice of three standard journal bearing diameters listed on pages 12 through 15. If the shaft cannot be machined to one of the standard diameters, Kingsbury offers at a modest fee the option of a custom-designed journal bearing to accommodate the shaft.

C Unit

Also available are separate self-aligning journal bearings. These model C bearings are assigned

designations similar to the CH unit. Typically at the inboard (drive) end of the machine, they are generally of the same design and size as the journal in the CH unit. These bearings depend on the CH bearing for lubrication. C bearing units may be purchased separately, but require an external lubrication system if a CH unit is not incorporated. To ensure proper lubrication, the piping to and from these bearings should conform to Kingsbury's guidelines as described under "Oil Piping", page 10.

Oil Circulator

The oil circulator is the heart of Kingsbury's CH system. Working in concert with the thrust collar to form a self-priming viscosity pump, it provides lubrication to the entire system by means of shaft rotation. As long as the shaft is rotating, pressurized oil is available, even during power outages or reverse rotation. It may even provide sufficient volume and pressure to lubricate additional, externally mounted equipment such as motor bearings or couplings. Please consult one of Kingsbury's sales engineers for an evaluation of your application.

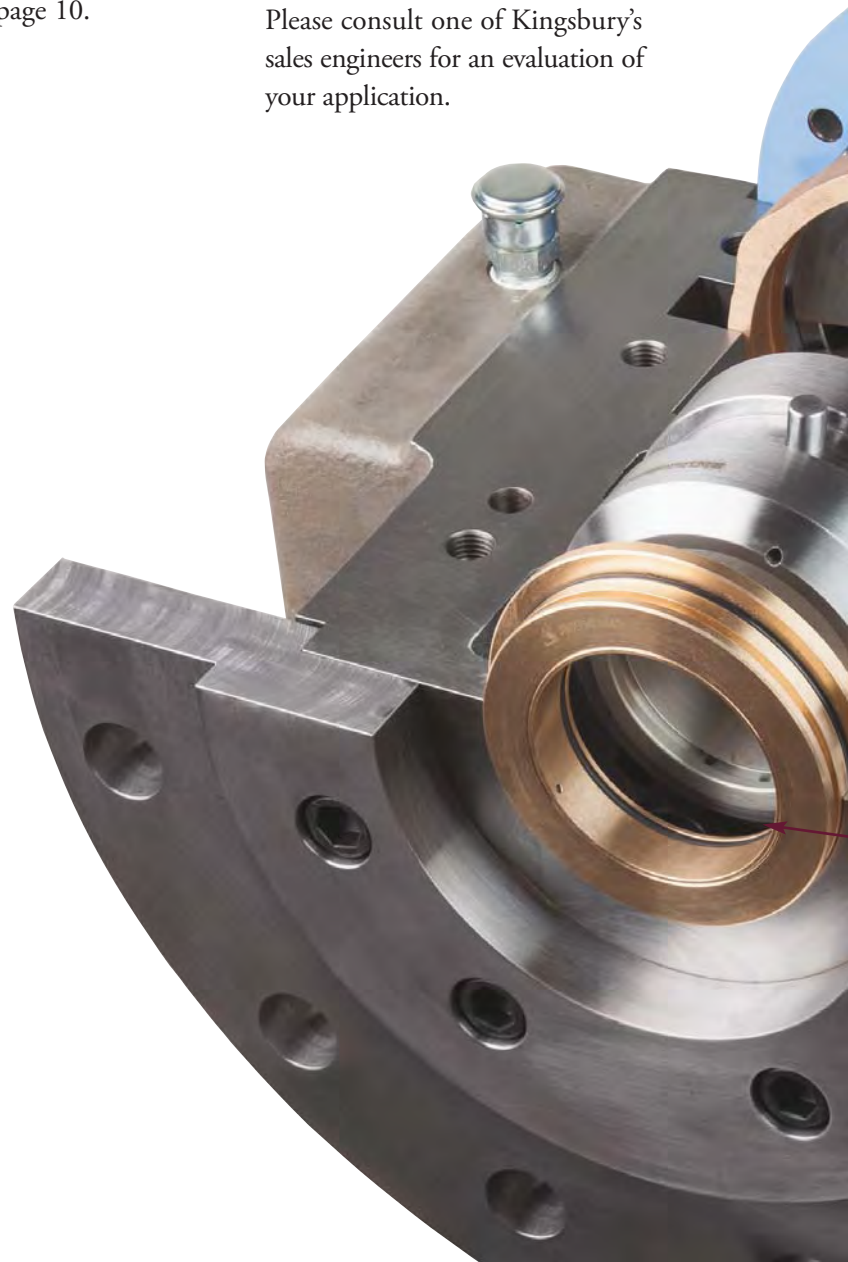

Cooling

Standard oil cooling is provided by means of a plate-style heat exchanger mounted directly on the CH unit, and requires fresh water typically supplied at a temperature of 30° C (85° F). Standard coolers can be provided to suit any speed within the catalog's published load and speed ranges. Shell-and-tube heat exchangers are also available for applications with special coolants

such as sea water, as is the option of forced-air cooling. See page 11 for additional information on oil cooling.

Standard Sizes/Capacities

Standard units listed in this catalog can accommodate thrust loads up to 180 kN (40,000 lbf), shaft sizes up to 190 mm (7.50"), and sliding velocities up to 65 m/s (215 ft/sec) at the mean diameter of the thrust collar.

Custom Designs

The self-lubricating system has been incorporated successfully in applications larger than those listed in this catalog, including pedestal-mounted housings for marine dredge pumps. Please consult our Sales Department for information on sizes and/or equipment not listed here.

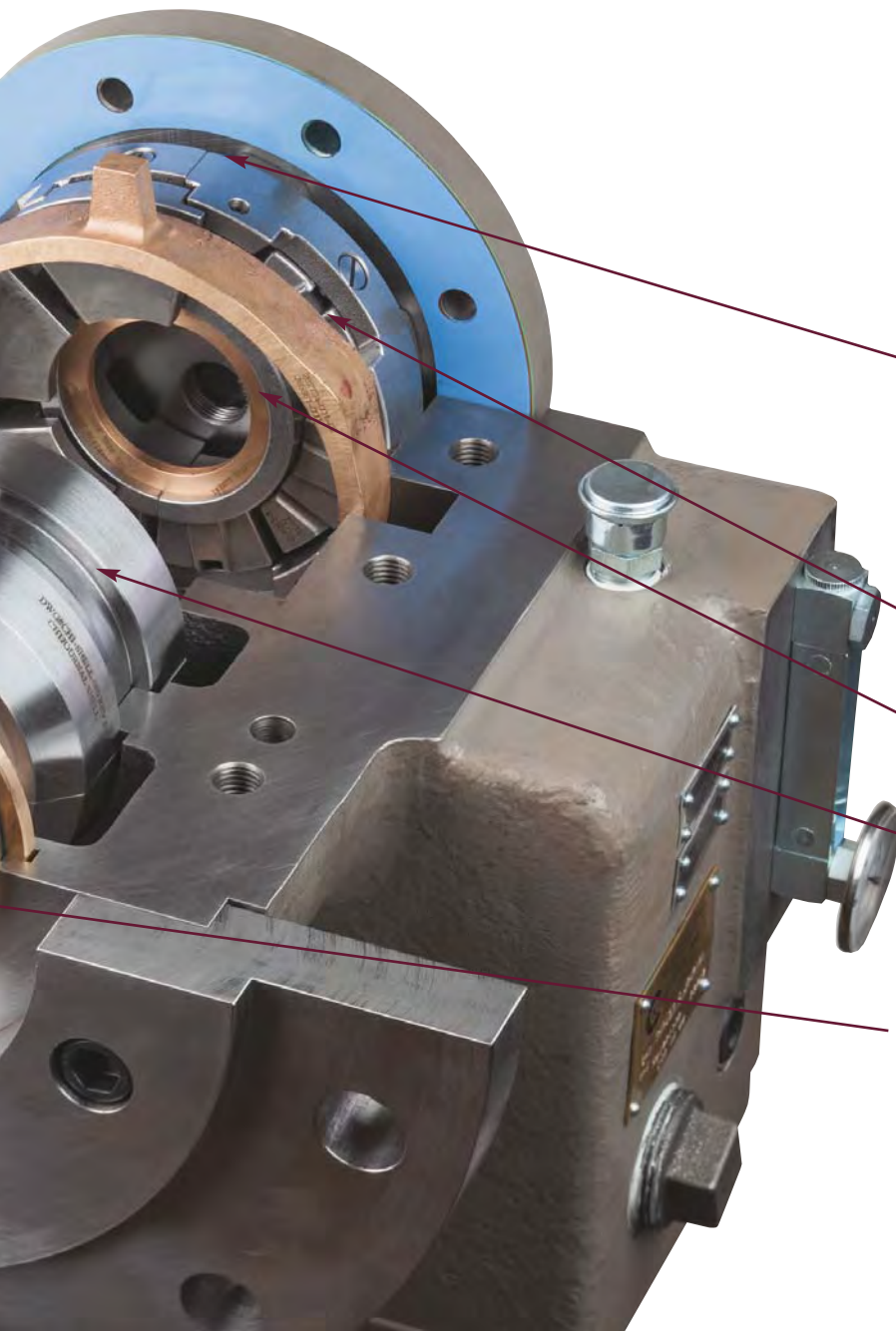

THRUST BEARING
(OUTBOARD SHOWN,
INBOARD BEARING
REMOVED FOR CLARITY)

OIL CIRCULATOR

OIL SEAL RING

JOURNAL BEARING

LABYRINTH END SEAL

HOW THE CH BEARING LUBRICATION SYSTEM WORKS

To view oil flow animations online, click on an image below. Animations will open in a new tab/window.



As the shaft begins to rotate, oil is drawn from the reservoir through a port in the oil circulator.

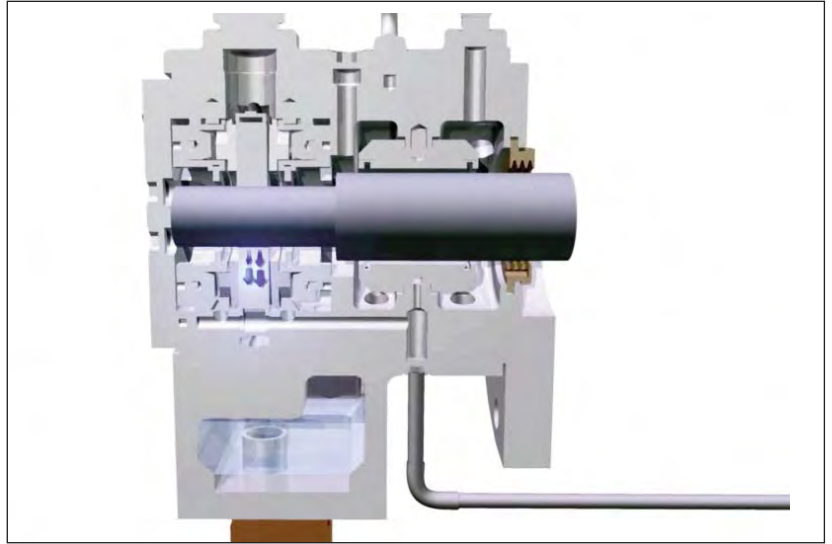

Cool oil travels around both thrust bearings as well a channel toward the integral journal bearing.

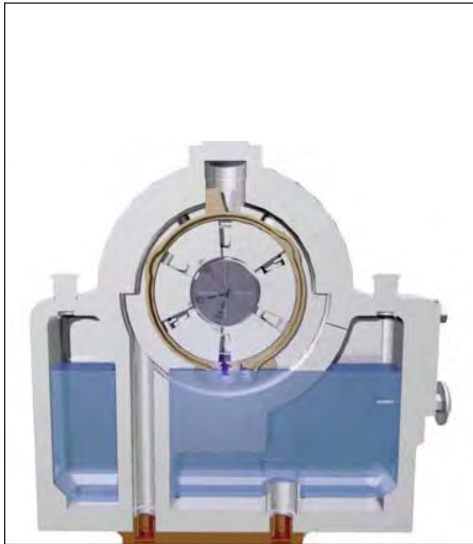

Pressurized oil from the central passage of the circulator enters the thrust bearings to be drawn across the shoes.

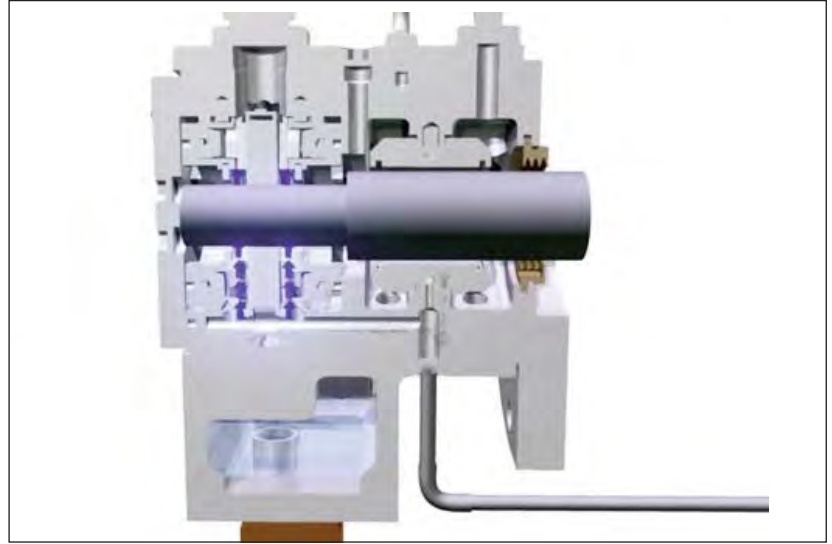

At the same time oil passes through the thrust bearings, pressurized oil flows around the journal bearing.

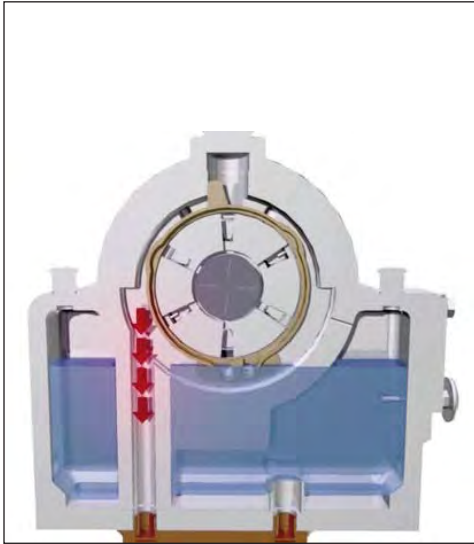

Hot oil from the thrust bearings returns to the heat exchanger through a standpipe.

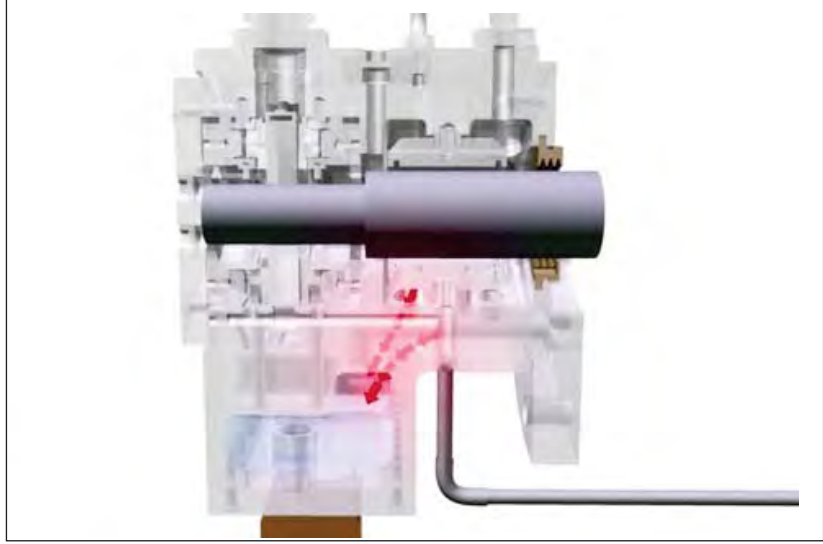

As pressurized oil is supplied to the integral journal in the CH unit, it also travels to the journal in the remote C bearing. Hot oil returns to the reservoir by customer-supplied piping.

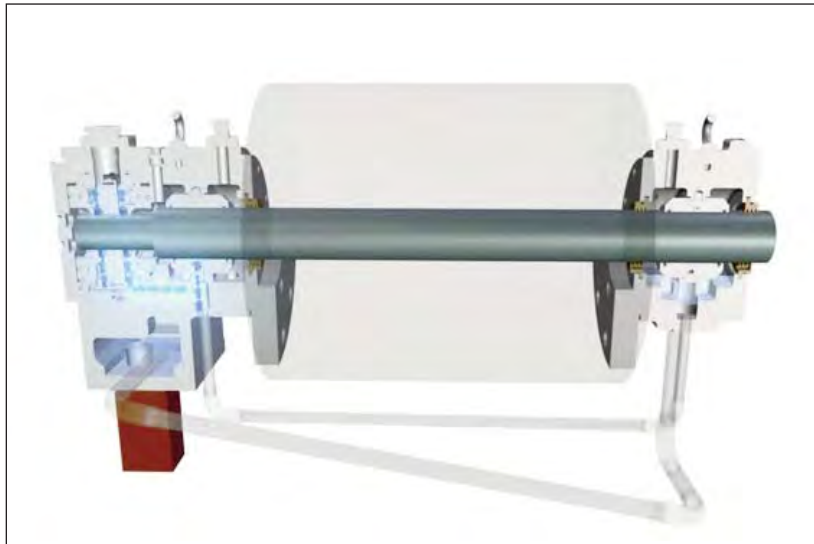

As pressurized oil is supplied to the integral journal in the CH unit, it also travels to the journal in the remote C bearing. Hot oil returns to the reservoir by customer-supplied piping.

BEARING SELECTION

Guidelines for assigning load capacities take several factors into consideration, including theoretical analyses, our field experience, and test results. Thrust bearing rated loads (page 14 or 15) have been calculated based on the following design considerations: on low-speed applications, the limiting factor is film thickness; on high-speed applications, the limiting factor is shoe temperature.

All the ratings published in this catalog have a factor of safety of at least two.

This complies with standard industry specifications, including those of the American Petroleum Institute.

For most typical applications, the determining factor in selecting a CH unit size is the required shaft diameter.

1. Using the shaft size limits indicated in our catalog drawings, determine the smallest CH unit that accommodates your shaft size.

2. Next, check the bearing thrust capacities versus required load demands. The selected unit should be capable of handling the maximum thrust load. Use the following figures as a guide:

- See page 14 or 15 for the Thrust Bearing Rated Load curve for ISO VG 46.
- See page 16 or 17 for the Thrust Bearings Friction Loss curve.

3. Finally, confirm the journal load capacity from



Photo copyright Sulzer Ltda., Jundiai, Brazil

page 16 or 18.

Example: Given a thrust load of 20,000 N (4500 lbf), shaft diameter at the journal of 80 mm (3.15”), a speed of 3600 rpm, and a journal load of 8000 N (1800 lbf).

Selection: From the tables on pages 12-13, select the smallest unit size with the correct shaft diameter. The smallest unit capable of handling the given shaft is a CH-1. Next, refer to Thrust Bearing Rated Load curve, page 14 or 15, to confirm that the CH-1 is acceptable. Note that it is more than adequate for the given thrust load. Finally, verify from Journal Bearing Rated Load curve, page 14 or 15, that the journal size is adequate for the specified load. Therefore, a CH-1 will be the best solution for the given data.

Oil Piping

Oil piping between the remote C and the CH is not supplied by

Kingsbury. Piping should be arranged with the C bearing return pipe going straight down far enough to give a continuous rise at a slope of between 5° and 8° to the CH unit. As the head pressure on the returning oil is slight, the return pipe must be adequately sized. Please refer to Sheet 1 of the C unit drawing (link on page 13) to determine the proper size. All oil piping must be installed well below the oil level. Trace heating on pipes and an oil heater in the CH sump are recommended if ambient temperatures are likely to go below 10° C (50° F) at startup.

Oil Cooling

The integral heat exchanger's unique design combines a high thermal efficiency with a minimal pressure drop. Optional arrangements include an all brass/bronze construction for seawater-cooling applications, and an all-ASTM A300-series stainless-steel construction. For

stainless-steel construction. For applications in which no cooling water is available, a forced-air oil cooler can be provided. Only the standard cooler and the all-brass coolers can be mounted directly to the CH unit. All other options must be remotely mounted as close as possible to the CH bearing. When the cooling water is thermostatically controlled, the flow rate must be set to maintain the sump at 50° C (120° F) or the temperature specified.

Oil Selection

The charts and tables in this catalog are based on an oil viscosity grade of ISO VG 46. However, other oil viscosity grades can be used. Their use is based largely on speed and load considerations. For example, ISO VG 32 is better suited for light loads and/or high speeds, whereas ISO VG 68 should be used if the loads are higher and the speeds slower. If unsure of the best oil viscosity for your application, please consult Kingsbury for a recommendation.

Since the Kingsbury CH Bearing System is entirely self-contained, continuous filtration is not required. Initial oil fill is to be filtered to 10 microns or better. See Table on pages 12 to 13 for CH housing oil sump capacities. Please add a sufficient amount of oil to these capacities to allow for the application's piping.

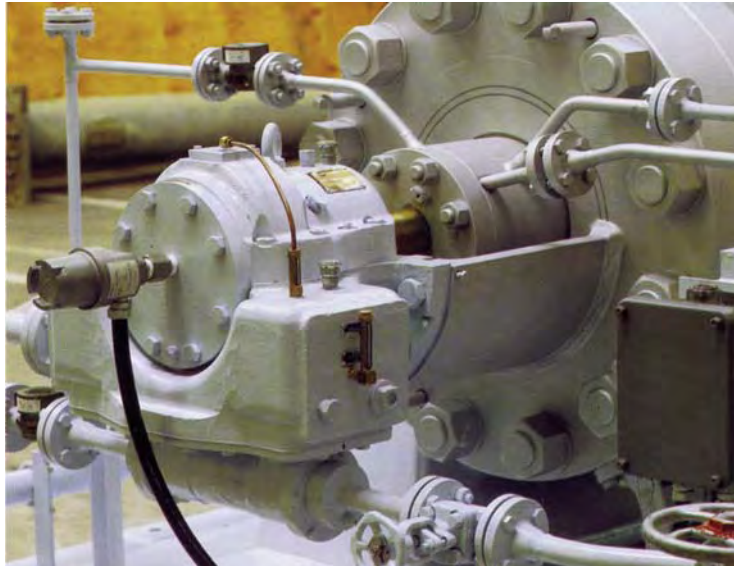

Caution: The piping can usually accommodate more oil than the sump itself.

Flange Options

Kingsbury's CH and C units are designed to give the customer considerable flexibility when selecting the type of flange for the application. The flange is designed and machined separately from the housing, and can be either a half or full circle, with the bolt circle of your choice. See individual drawings for more details on flange selection.

Shaft and Collar Details

Typically, Kingsbury will supply a separate thrust collar. We recommend that the collars have a sliding fit (ANSI Class RC2) on the shaft. User must provide the shaft nut, nut locking device, and key. Details of the arrangement

are shown on the individual drawings. Details of the arrangement are on page 13.

Paint

All units come painted on the exterior with a gray metal primer and the internal unmachined oil-containing surfaces painted with an insulating enamel. Attached coolers come painted with a styrenated alkyd enamel. All exterior surfaces that are painted can be re-coated.

CH BEARING DIMENSIONAL DATA

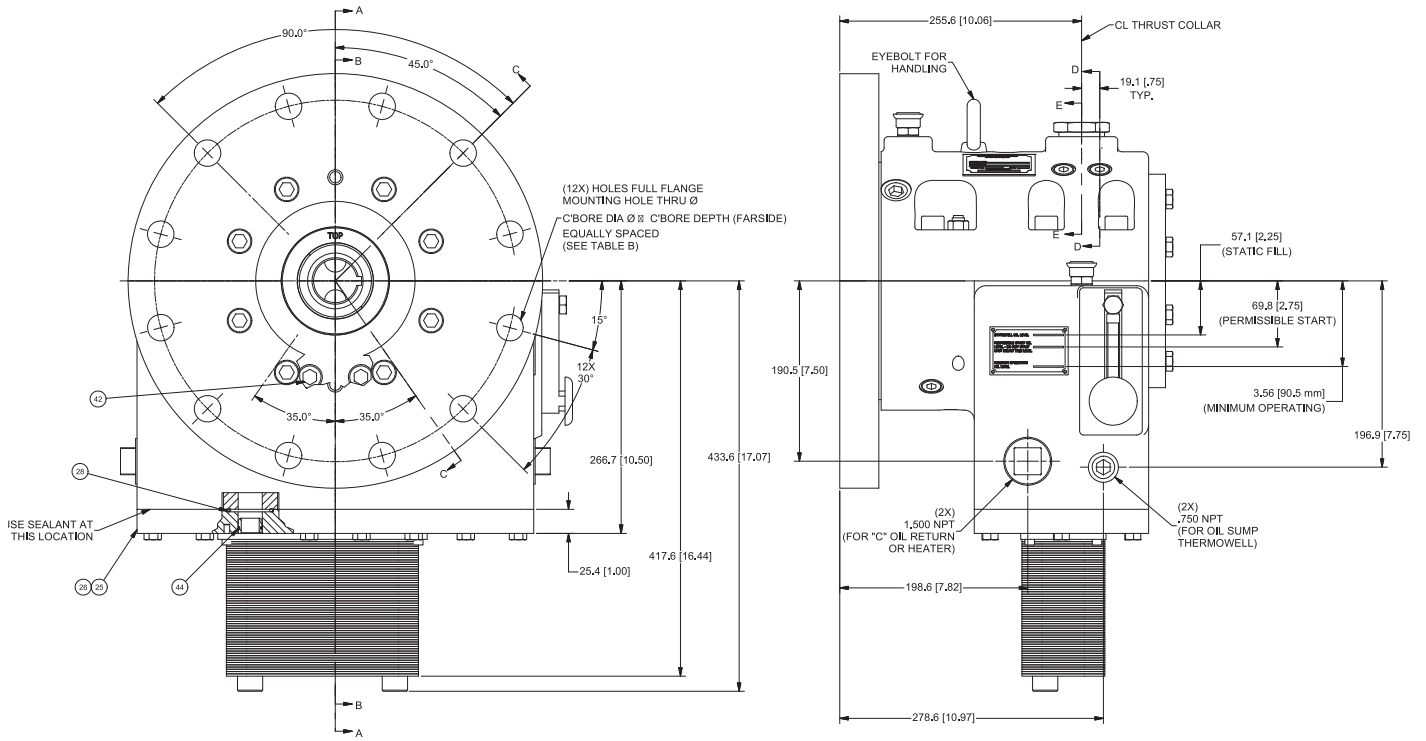

To view detailed dimension drawings, visit http://kingsbury.com/file_library.shtml

CH Bearing Size 1

60 mm – 70 mm – 80 mm

CH Bearing Size 3

110 mm – 130 mm – 150 mm

CH Bearing Size 2

80 mm – 95 mm – 110 mm

CH Bearing Size 4

150 mm – 170 mm – 190 mm

C BEARING DIMENSIONAL DATA

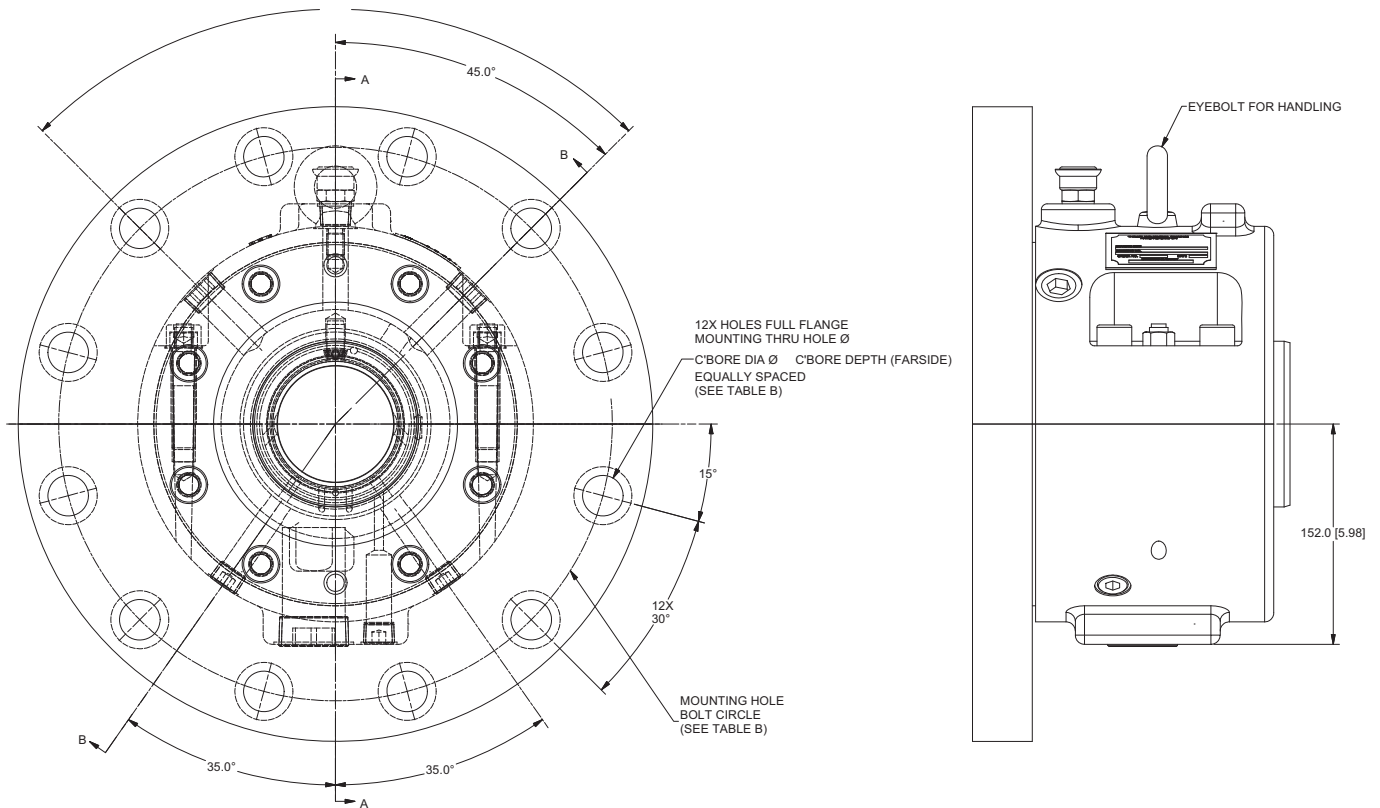

To view detailed dimension drawings, visit
http://kingsbury.com/file_library.shtml

C Bearing Size 1

60 mm – 70 mm – 80 mm

C Bearing Size 3

110 mm – 130 mm – 150 mm

C Bearing Size 2

80 mm – 95 mm – 110 mm

C Bearing Size 4

150 mm – 170 mm – 190 mm

PERFORMANCE DATA CURVES

RATED LOAD FOR CH SYSTEM THRUST BEARINGS (METRIC)

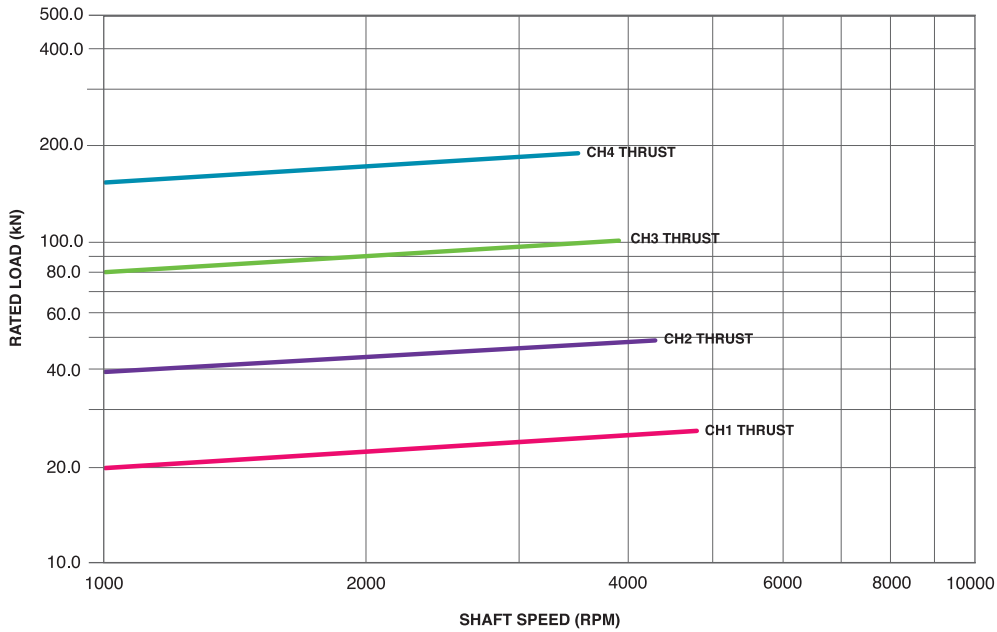

Based on ISO VG 46 oil at 49°C sump temperature

RATED LOAD FOR CH SYSTEM JOURNAL BEARINGS (METRIC)

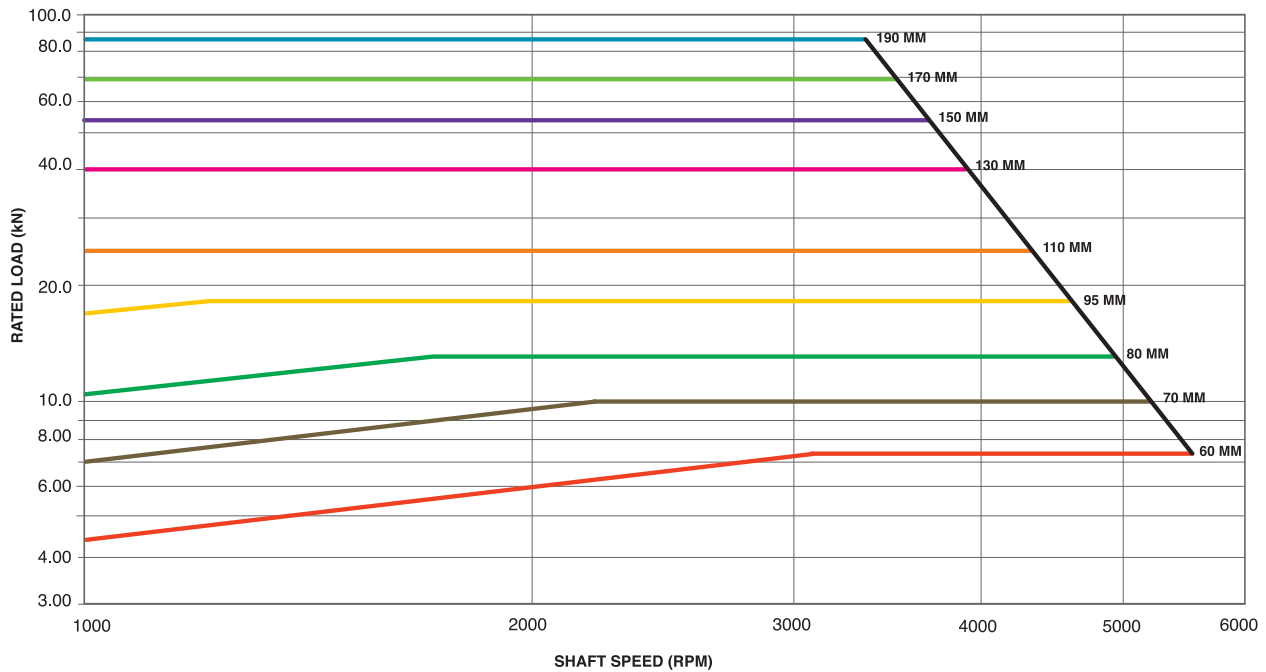

Based on ISO VG 46 oil at 49°C sump temperature at the journal mean diameter

RATED LOAD FOR CH SYSTEM THRUST BEARINGS (AMERICAN STANDARD)

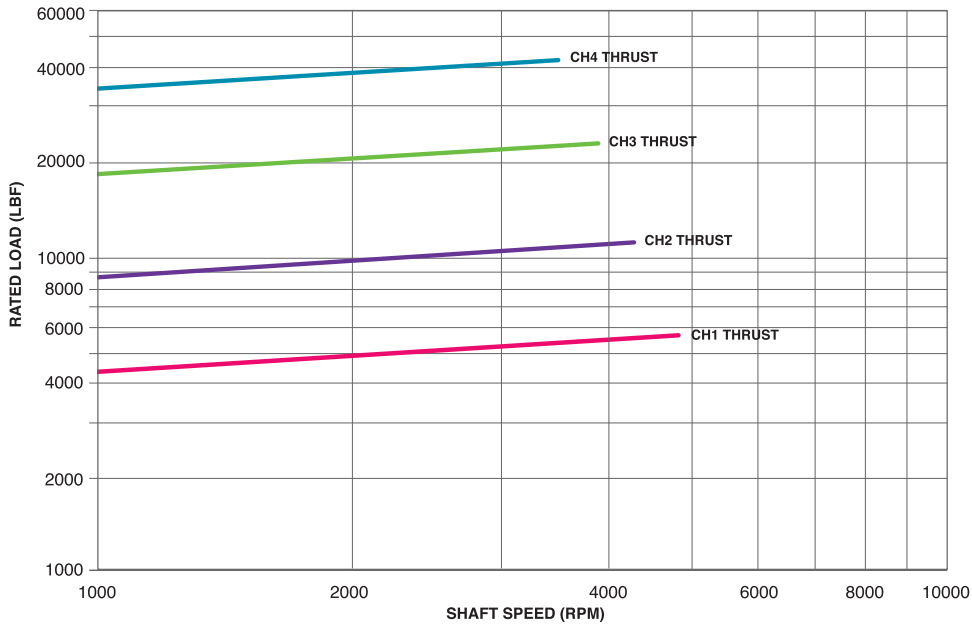

RATED LOAD FOR CH SYSTEM JOURNAL BEARINGS (AMERICAN STANDARD)

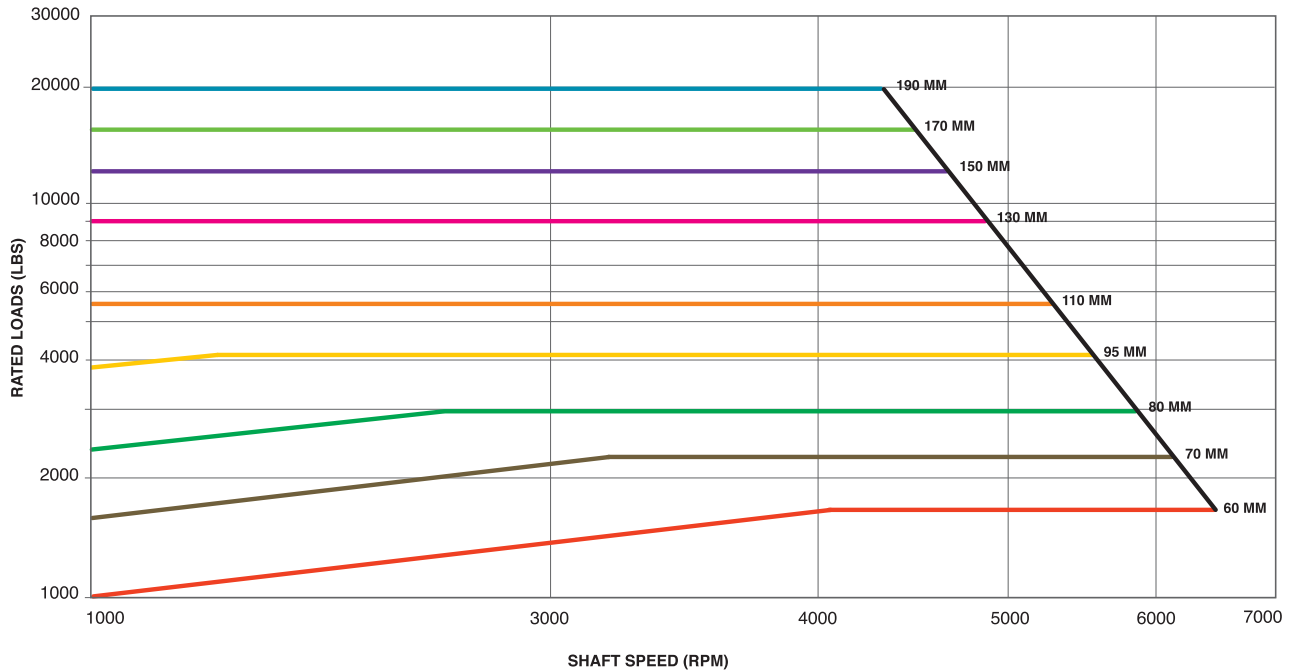

TOTAL FRICTIONAL LOSS FOR CH SYSTEM (METRIC)

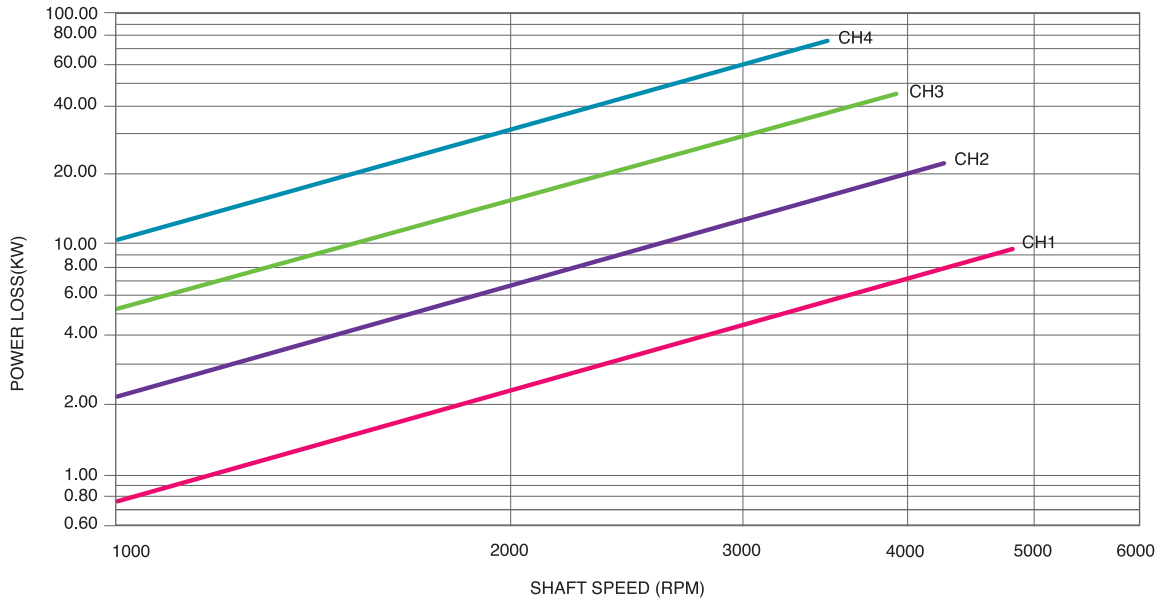

Based on rated thrust and journal loads, ISO VG 46 oil, 49°C sump temperature

RECOMMENDED COOLING WATER FLOW FOR CH SYSTEM (METRIC)

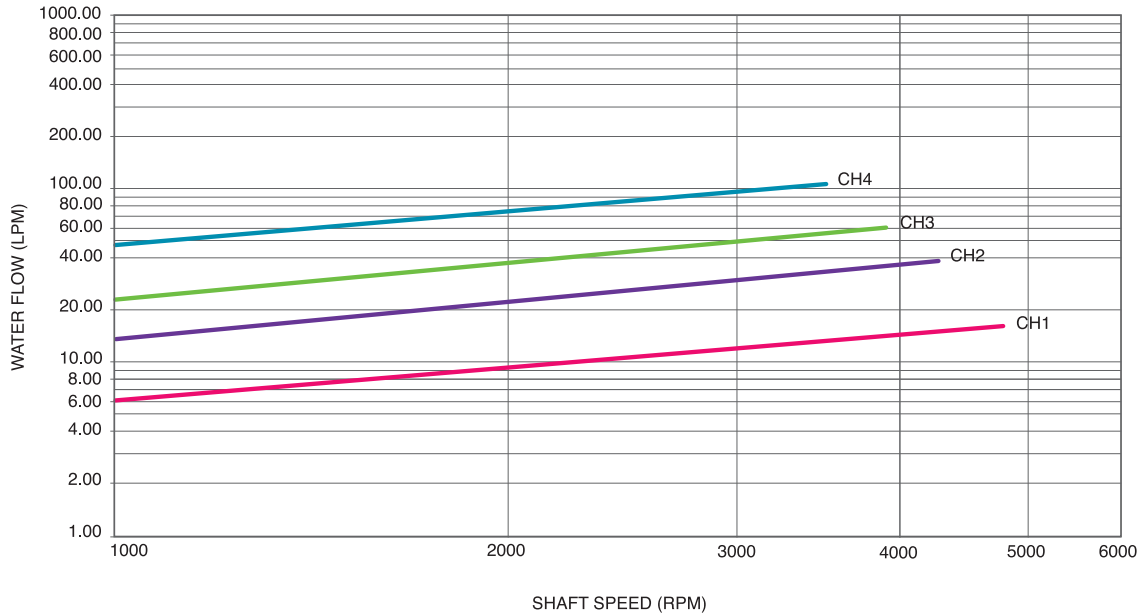

Based on rated loads, standard cooler, ISO VG 46 oil at 49°C inlet, 27°C cooling water

TOTAL FRICTIONAL LOSS FOR CH SYSTEM (AMERICAN STANDARD)

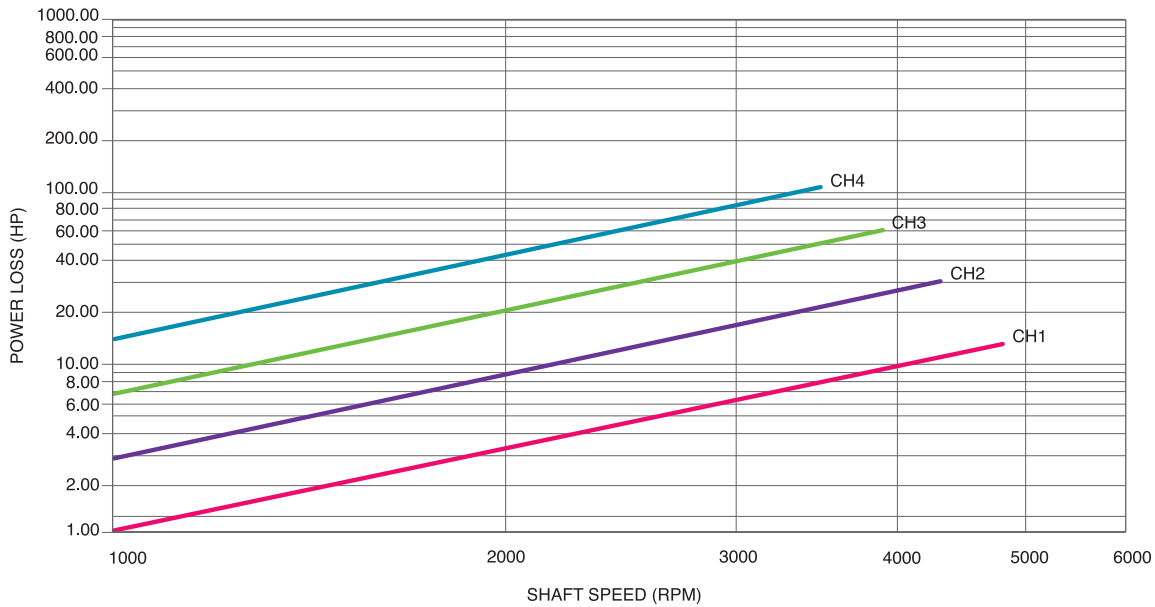

Based on rated thrust and journal loads, ISO VG 46 oil, 120°F sump temperature

RECOMMENDED COOLING WATER FLOW FOR CH SYSTEM (AMERICAN STANDARD)

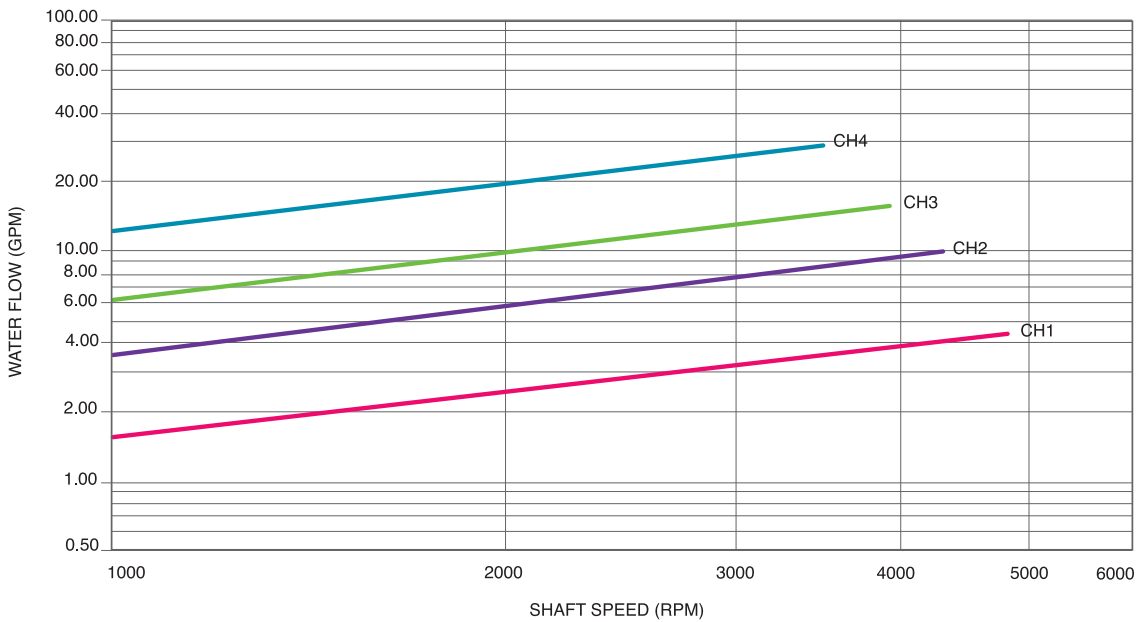

Based on rated loads, standard cooler, ISO VG 46 oil at 120°F inlet, 80°F cooling water

OPTIONS AND INSTRUMENTATION

BASIC MODEL

Standard CH and C units are supplied with the option of a half or full flange, a flat or spigot mount, labyrinth or Inpro® end seals, as well as provisions for temperature detectors, axial and radial vibration probes, and lifting bolts. Each housing configuration allows for three standard shaft diameters, which can be adapted to accommodate special customer requirements if necessary. Please refer to the drawings on pages 12 to 13 for all standardized options.

INSTRUMENTATION

Instrumentation taps can be provided for temperature sensing, vibration monitoring, and phase reference monitoring. Please see the callouts indicated on the photos for tap options and locations. Kingsbury can also provide instrumentation, if requested.

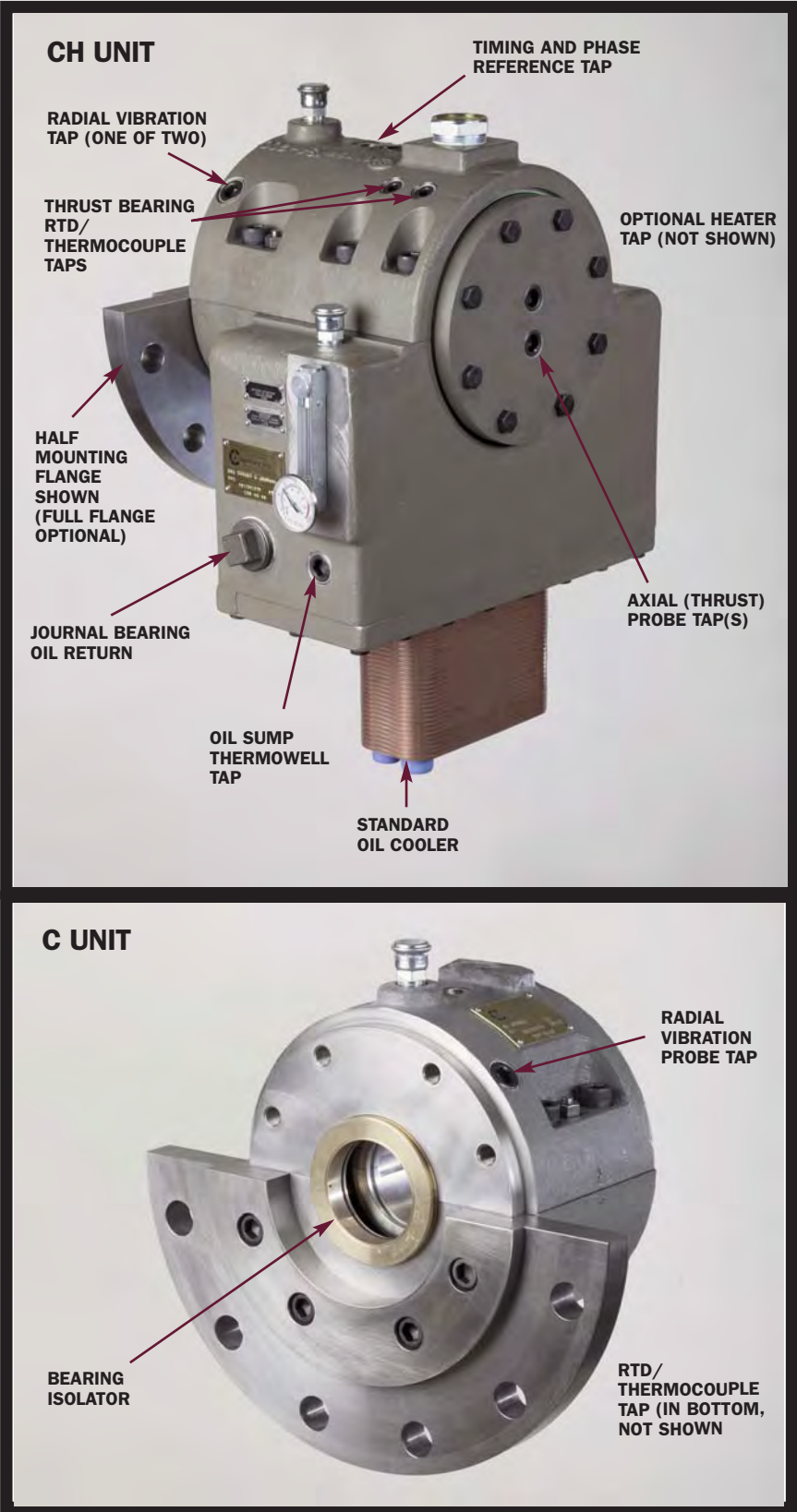



10385 Drummond Road
Philadelphia, PA 19154 USA
Telephone: +1 215-824-4000
Fax: +1 215-824-4999
www.kingsbury.com